

SUBMITTAL - 18,000BTU CEILING CASSETTE - E25

Job Name: _____
Location: _____
Engineer: _____
Submitted By: _____
Submitted To: _____

Submitted For: _____ **Approval**
Reference **Construction**
Date: _____
Unit Tag: _____
Drawing No.: _____

WARRANTY

1 Year Parts & 5 Years Compressor

Terms & Conditions Apply.

TYPE

Air Source Heat Pump

Cold Climate Air Source Heat Pump

MODELS

Indoor DUA18HICU230X5

Outdoor DEA18HOS25230E8

CAPACITY RANGE¹

Output (Btu/h)	Min.	Rated	Max.
Cooling	4000	16000	16000
Heating	5700	19000	19000

HEATING PERFORMANCE²

Output (Btu/h)	Min.	Rated	Max.
47°F (8.3°C)	5700	19000	19000
17°F (-8.3°C)	3600	12000	13600
5°F (-15°C)	2600	12700	12700
-13°F (-25°C)	1200	6500	6500

OUTDOOR TEMPERATURE OPERATING RANGE

Cooling	-25 ~ 50 °C	-13 ~ 122 °F
Heating ³	-25 ~ 24 °C	-13 ~ 75 °F

LINE SET & REFRIGERANT

Liquid (in.)	1/4"	Gas (in.)	1/2"
Connection Type	Flared		
Pre-Charge Length (ft)	25		
Max. Length (ft)	98.4		
Max. Height Difference (ft)	65.6		
Refrigerant Type	R410A		
Pre-Charge (oz)	56.44		
Additional Charge per Foot (oz)	0.16		
Oil Type	VG74	Oil Volume (ml)	440
Drain Pipe O.D. (mm)	25		

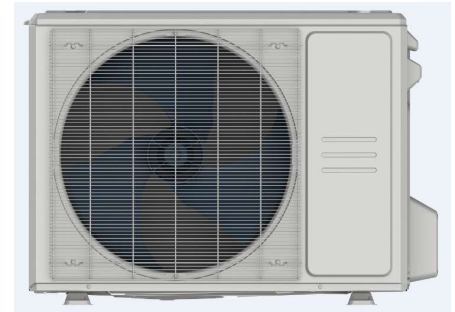

Images for reference only.

CERTIFIED

AHRI NO.
207742435



EFFICIENCY RATINGS

SEER2	20.5			
EER2	12.5			
HSPF2 (4)	10.5			
HSPF2 (5)	8			
COP ²	47°F (8.3°C)	17°F (-8.3°C)	5°F (-15°C)	-13°F (-25°C)
	2.78	2.51	2.16	1.5

ELECTRICAL

Power Supply	(V/Ph/Hz)	208-230/1/60		
Voltage Range	(V)	187-253		
MCA (A)	19	Max Fuse (ODU) (A)	30	
Power Input (W)	Min.	Rated	Max.	
	Cooling	230	1340	1340
Heating	470	1950	1950	
Current (A)	Min.	Rated	Max.	
	Cooling	1.9	6	6.01
Heating	3.23	8.21	8.21	

1. Cooling Capacity Conditions: Indoor Temperature @ 80°F (26.7°C) DB; 67°F (19.4°C) WB with Outdoor Temperature @ 95°F (35°C) DB; 75°F (23.9°C) WB. Heating Capacity Conditions: Indoor Temperature @ 70°F (21.1°C) DB; 60°F (15.6°C) WB with Outdoor Temperature @ 47°F (8.3°C) DB; 43°F (6.1°C) WB. Line Set @ 25ft (7.5m); Height Difference @ 0ft (0m). 2. COP for all temperatures is @ rated output except when rated output is not given. In that case, COP is @ max. output. 3. System continues to operate below rated outdoor temperature operating range, subject to varying conditions. System has no low temperature cutout. Capacity is not tested outside of the rated temperature range. | Master Group is not responsible for the accuracy and validity of any changes made to this document without the written authorization of Master Group. Specifications subject to change without notice.

DIMENSIONS & WEIGHTS		
Indoor	Net (WxDxH; in.)	22.44x22.44x10.24
	Gross (WxDxH; in.)	26.06x26.06x12.48
	Net Weight lbs kg	35.71 16.2
	Gross Weight lbs kg	46.96 21.3
Outdoor	Net (WxDxH; in.)	35.04x13.46x26.50
	Gross (WxDxH; in.)	39.17x15.67x29.13
	Net Weight lbs kg	94.36 42.8
	Gross Weight lbs kg	100.97 45.8

KEY FEATURES	
Rotary Inverter Compressor	<input checked="" type="checkbox"/>
Twin Rotary Inverter Compressor	<input type="checkbox"/>
Base Pan Heater	<input checked="" type="checkbox"/>
Crankcase Heater	<input checked="" type="checkbox"/>

INCLUDED ACCESSORIES	
RG10B(D1)/BGEFU1 - Remote Controller	

FAN				
Indoor	Turbo	High	Med.	Low
CFM		562	485	438
dB(A)		46	41.5	39.5
Indoor ESP Range inWG				
Indoor Moisture Removal (l/h)				2.27
Outdoor Max. CFM				2059
Outdoor Max. dB(A)				60.5

OPTIONAL ACCESSORIES ⁴	
CASSETTEGRILL918A - Required	<input type="checkbox"/>
WF-60A1-F - Smart Port	<input type="checkbox"/>
KJR-120L(R1)/EFU1 - Wired Controller	<input type="checkbox"/>
KJR-120N(X6)/BGEF - Wired Controller	<input type="checkbox"/>
KJR-120N(X6W)/BGEF - Wired Controller	<input type="checkbox"/>
24VINTERFACEKITUNIVERSAL	<input type="checkbox"/>
	<input type="checkbox"/>
	<input type="checkbox"/>
	<input type="checkbox"/>
	<input type="checkbox"/>

INDOOR UNIT DRAWING

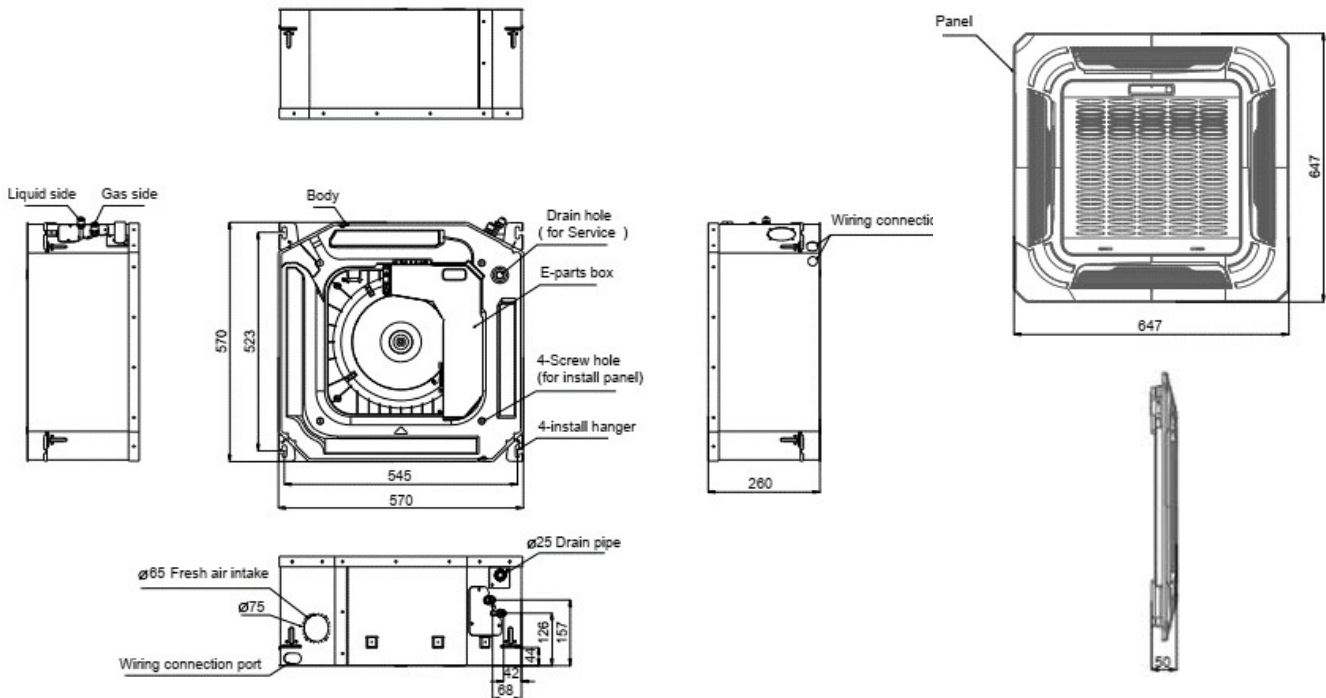

Tag										
inches										
mm										

Drawing dimensions are nominal. Specifications subject to change without notice. 4. Connection of these accessories may require secondary items not listed; refer to full product literature.

OUTDOOR UNIT DRAWING

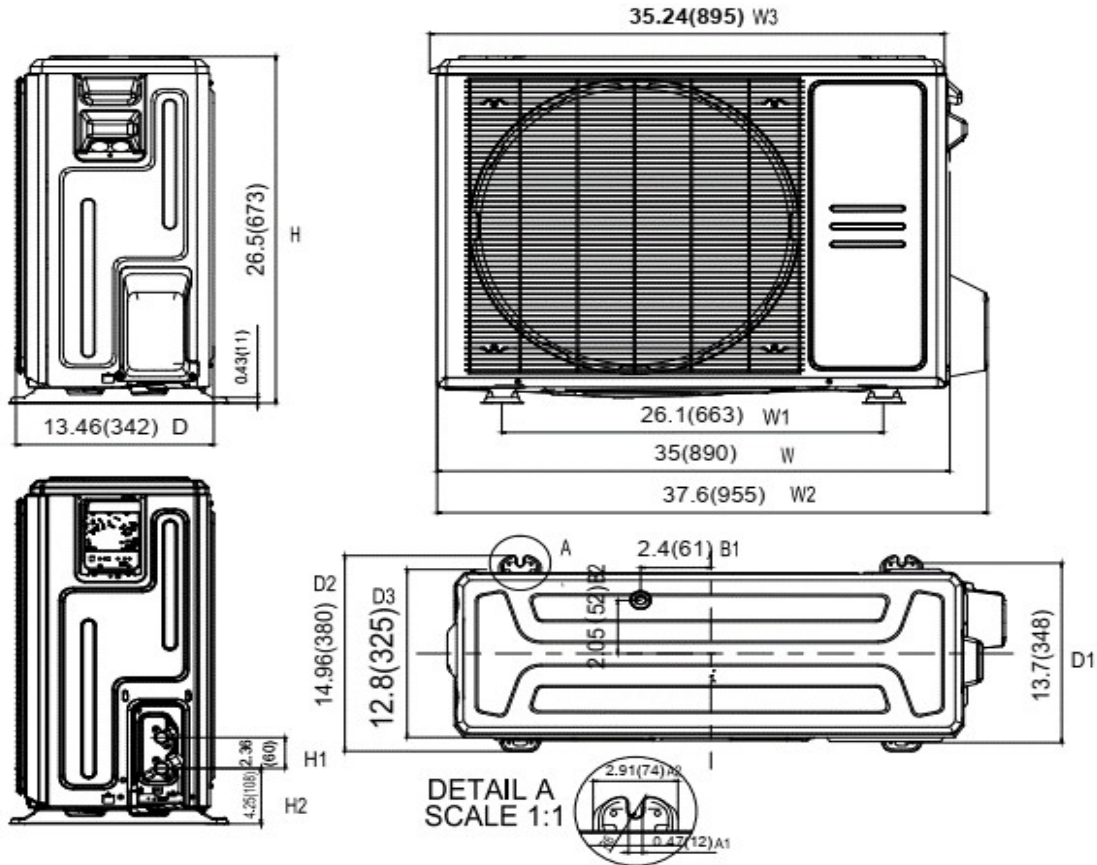

OUTDOOR UNIT CLEARANCES

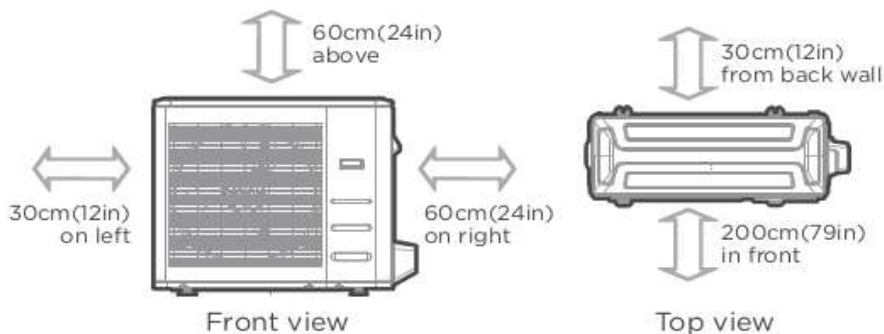

Note: Outdoor units must be elevated 12-24in. (30.5-61cm) above the surface below in heating applications to allow for snow clearance and defrost runoff. Follow local best-practices and guidelines.

Diagrams for reference only.

NOTES