

# SUBMITTAL - 24,000BTU MULTI-POSITION AHU

**Job Name:** \_\_\_\_\_  
**Location:** \_\_\_\_\_  
**Engineer:** \_\_\_\_\_  
**Submitted By:** \_\_\_\_\_  
**Submitted To:** \_\_\_\_\_

**Submitted For:**  **Approval**  
**Reference**  **Construction**   
**Date:** \_\_\_\_\_  
**Unit Tag:** \_\_\_\_\_  
**Drawing No.:** \_\_\_\_\_

### WARRANTY

1 Year Parts & 5 Years Compressor  
 Terms & Conditions Apply.

### TYPE

Air Source Heat Pump   
 Cold Climate Air Source Heat Pump

### MODELS

Indoor	FEA24HIAHUU230X7
Outdoor	DEA24HOS20230E7

### CAPACITY RANGE<sup>1</sup>

Output (Btu/h)	Min.	Rated	Max.
Cooling	8900	24000	27000
Heating	7100	24000	31000

### HEATING PERFORMANCE<sup>2</sup>

Output (Btu/h)	Min.	Rated	Max.
47°F (8.3°C)	7100	24000	31000
17°F (-8.3°C)	8333	19200	26400
5°F (-15°C)	6000	22600	24071
-22°F (-30°C)	5800	13400	13400

### OUTDOOR TEMPERATURE OPERATING RANGE

Cooling	-15 ~ 50 °C	5 ~ 122 °F
Heating	-30 ~ 24 °C	-22 ~ 75 °F

### LINE SET & REFRIGERANT

Liquid (in.)	3/8"	Gas (in.)	3/4"
Connection Type	Flared		
Pre-Charge Length (ft)	25		
Maximum Length (ft)	164.04		
Maximum Height Difference (ft)	82.02		
Refrigerant Type	R410A		
Pre-Charge (oz)	102.32		
Additional Charge per Foot (oz)	0.69		
Oil Type	VG74	Oil Volume (ml)	670
Drain Connection (inches)	3/4"		



Images for reference only.

### CERTIFIED

AHRI NO.	
213081442	

### EFFICIENCY RATINGS

SEER2	17.4			
EER2	11.7			
HSPF2 (4)	10			
HSPF2 (5)	8			
COP <sup>2</sup>	47°F (8.3°C)	17°F (-8.3°C)	5°F (-15°C)	-22°F (-30°C)
	3.35	2.5	1.91	1.41

### ELECTRICAL

Power Supply	(V/Ph/Hz)	208-230/1/60		
Voltage Range	(V)	187-253		
MCA (A)	20	Max Fuse (ODU) (A)	35	
Power Input (W)	Min.	Rated	Max.	
	Cooling	740	2050	2450
Heating	660	2100	2900	
Current (A)	Min.	Rated	Max.	
	Cooling	5.3	9.1	11
Heating	4.87	9.3	12.9	

1. Cooling Capacity Conditions: Indoor Temperature @ 80°F (26.7°C) DB; 67°F (19.4°C) WB with Outdoor Temperature @ 95°F (35°C) DB; 75°F (23.9°C) WB. Heating Capacity Conditions: Indoor Temperature @ 70°F (21.1°C) DB; 60°F (15.6°C) WB with Outdoor Temperature @ 47°F (8.3°C) DB; 43°F (6.1°C) WB. Line Set @ 25ft (7.5m); Height Difference @ 0ft (0m). 2. COP for all temperatures is @ rated output except when rated output is not given. In that case, COP is @ max. output. | Master Group is not responsible for the accuracy and validity of any changes made to this document without the written authorization of Master Group. Specifications subject to change without notice.

DIMENSIONS & WEIGHTS			
Indoor	Net (WxDxH; in.)	17.52x21.02x45.00	
	Gross (WxDxH; in.)	20.87x26.57x48.62	
	Net Weight lbs   kg	105.6	47.9
	Gross Weight lbs   kg	127.43	57.8
Outdoor	Net (WxDxH; in.)	37.24x16.14x31.89	
	Gross (WxDxH; in.)	42.91x19.69x34.84	
	Net Weight lbs   kg	136.69	62
	Gross Weight lbs   kg	145.5	66

KEY FEATURES	
Rotary Inverter Compressor	<input type="checkbox"/>
Twin Rotary Inverter Compressor	<input checked="" type="checkbox"/>
Base Pan Heater	<input checked="" type="checkbox"/>
Crankcase Heater	<input checked="" type="checkbox"/>

INCLUDED ACCESSORIES	
RG10A(D2S)/BGEFU1 - Remote Controller	
KJR-120N(X6W)/BGEF V1.2 - Wired Controller	
Adaptor for welding(3/8")	
Adaptor for welding(3/4")	

### INDOOR UNIT DRAWING

FAN				
Indoor	Turbo	High	Med.	Low
CFM	823	758	694	629
dB(A)		39	36	33
Indoor ESP Range inWG				0-0.80
Indoor Moisture Removal (l/h)				1.98
Outdoor Max. CFM				3000
Outdoor Max. dB(A)				62

OPTIONAL ACCESSORIES	
EAH-05B(UL) - 5kW Electric Heater Kit	<input type="checkbox"/>
EAH-10B(UL) - 10kW Electric Heater Kit	<input type="checkbox"/>
EAH-15B(UL) - 15kW Electric Heater Kit	<input type="checkbox"/>
	<input type="checkbox"/>
	<input type="checkbox"/>
	<input type="checkbox"/>
	<input type="checkbox"/>
	<input type="checkbox"/>
	<input type="checkbox"/>
	<input type="checkbox"/>

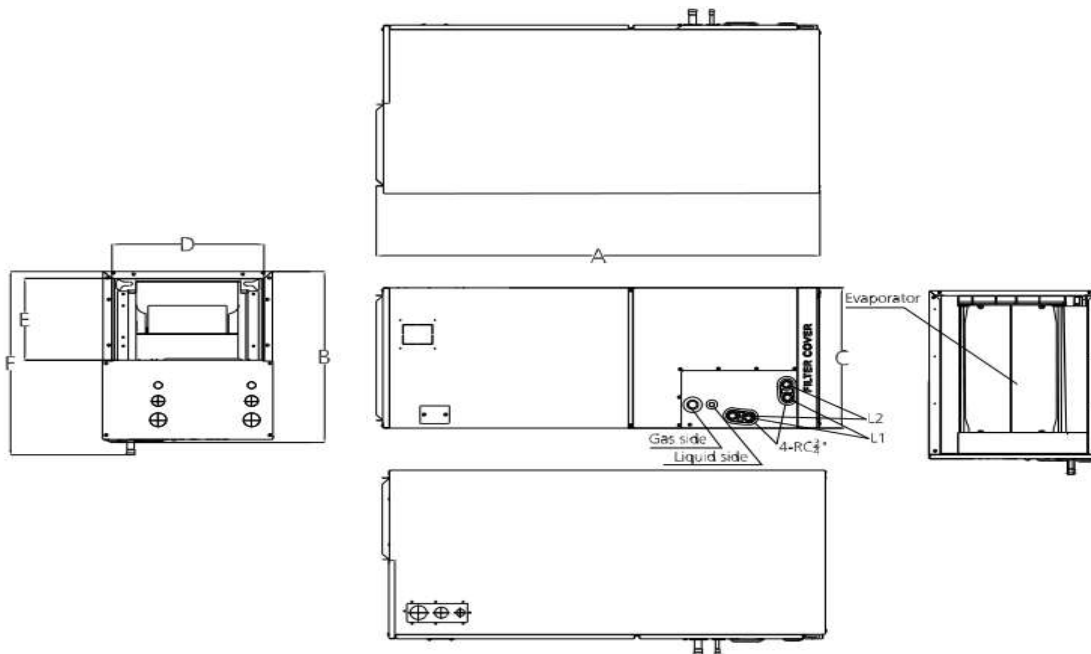

Dimensions D and E are air outlet dimensions.

Tag	A	B	C	D	E	F		L1	L2
inches	45	21	17-1/2	15-3/4	10-1/4	23		Main Drain	Overflow Drain
mm	1143	534	445	400	260	585		Drain	Drain

Drawing dimensions are nominal. Specifications subject to change without notice.

**OUTDOOR UNIT DRAWING**

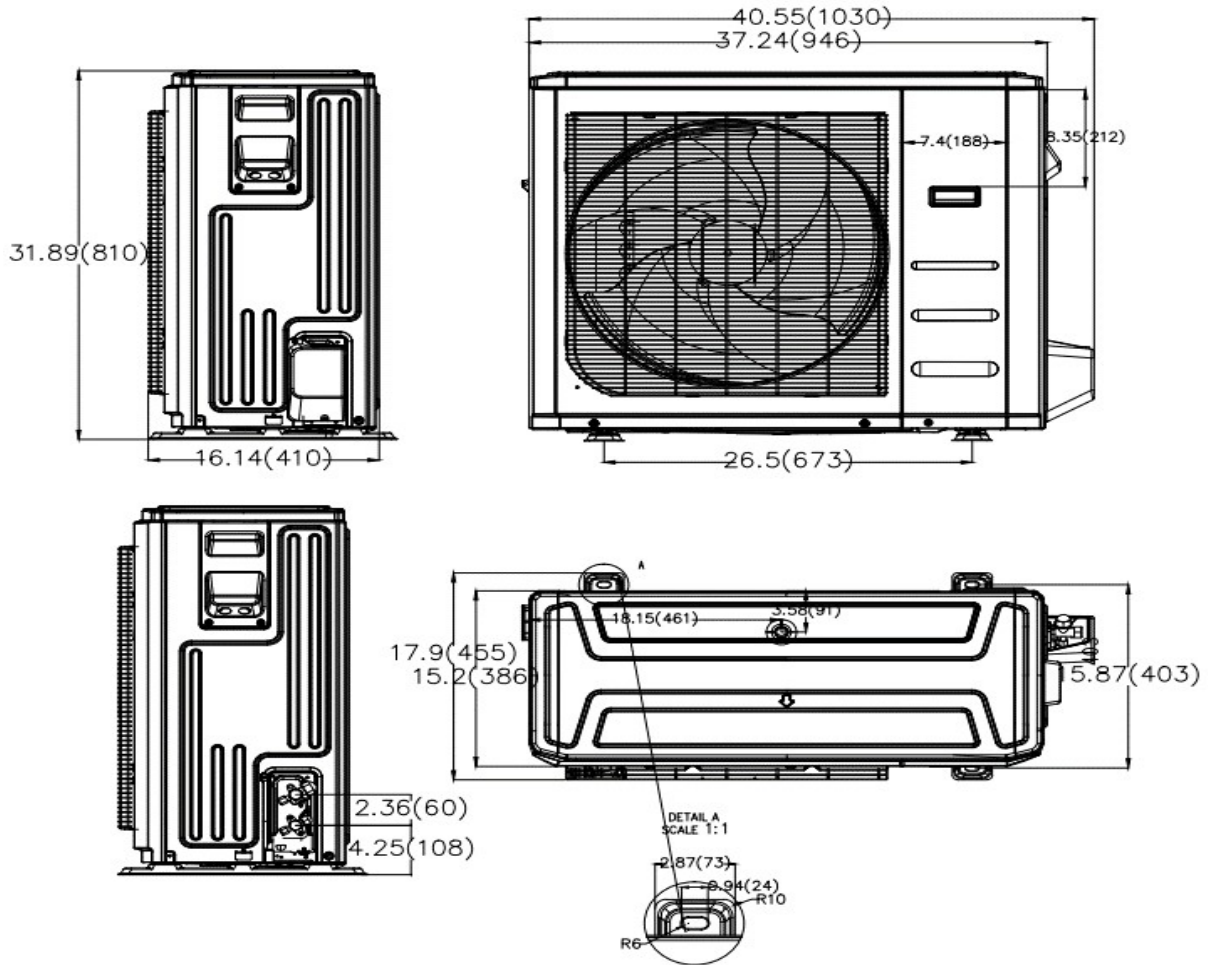

**OUTDOOR UNIT CLEARANCES**

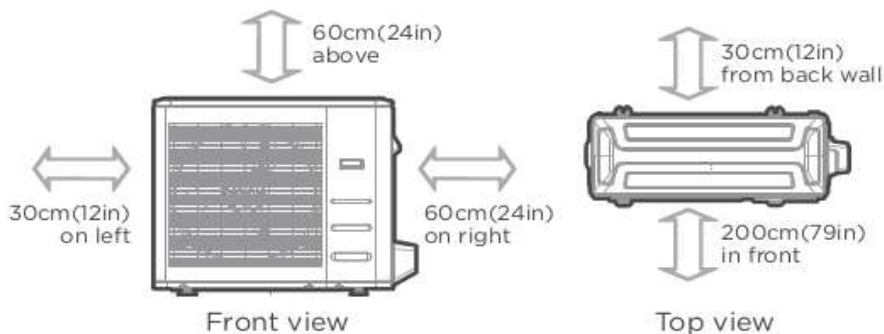

Note: Outdoor units must be elevated 12-24in. (30.5-61cm) above the surface below in heating applications to allow for snow clearance and defrost runoff. Follow local best-practices and guidelines.

Diagrams for reference only.

**NOTES**