

SUBMITTAL - 24,000BTU DUCTED - E25

Job Name: _____
Location: _____
Engineer: _____
Submitted By: _____
Submitted To: _____

Submitted For: _____ **Approval**
Reference **Construction**
Date: _____
Unit Tag: _____
Drawing No.: _____

WARRANTY

1 Year Parts & 5 Years Compressor

Terms & Conditions Apply.

TYPE

Air Source Heat Pump

Cold Climate Air Source Heat Pump

MODELS

Indoor DUA24HIDU230X5

Outdoor DEA24HOS25230E8

CAPACITY RANGE¹

Output (Btu/h)	Min.	Rated	Max.
Cooling	6100	23000	28200
Heating	7500	25000	33000

HEATING PERFORMANCE²

Output (Btu/h)	Min.	Rated	Max.
47°F (8.3°C)	7500	25000	33000
17°F (-8.3°C)	5900	20000	22600
5°F (-15°C)	5000	20000	20000
-13°F (-25°C)	2800		10500

OUTDOOR TEMPERATURE OPERATING RANGE

Cooling	-25 ~ 50 °C	-13 ~ 122 °F
Heating ³	-25 ~ 24 °C	-13 ~ 75 °F

LINE SET & REFRIGERANT

Liquid (in.)	3/8"	Gas (in.)	5/8"
Connection Type	Flared		
Pre-Charge Length (ft)	25		
Maximum Length (ft)	164		
Maximum Height Difference (ft)	82		
Refrigerant Type	R410A		
Pre-Charge (oz)	82.89		
Additional Charge per Foot (oz)	0.32		
Oil Type	VG74	Oil Volume (ml)	620
Drain Pipe O.D. (mm)	25		



Images for reference only.

CERTIFIED

AHRI NO.	
207742448	

EFFICIENCY RATINGS

SEER2	19			
EER2	12.5			
HSPF2 (4)	11.2			
HSPF2 (5)	8.8			
COP ²	47°F (8.3°C)	17°F (-8.3°C)	5°F (-15°C)	-13°F (-25°C)
	3.61	2.61	2.3	1.51

ELECTRICAL

Power Supply	(V/Ph/Hz)	208-230/1/60		
Voltage Range	(V)	187-253		
MCA (A)	22	Max Fuse (ODU) (A)	30	
Power Input (W)	Min.	Rated	Max.	
	Cooling	290	1840	2680
Heating	650	2030	2660	
Current (A)	Min.	Rated	Max.	
	Cooling	2.1	8.5	11.8
Heating	4.4	9.3	11.7	

1. Cooling Capacity Conditions: Indoor Temperature @ 80°F (26.7°C) DB; 67°F (19.4°C) WB with Outdoor Temperature @ 95°F (35°C) DB; 75°F (23.9°C) WB. Heating Capacity Conditions: Indoor Temperature @ 70°F (21.1°C) DB; 60°F (15.6°C) WB with Outdoor Temperature @ 47°F (8.3°C) DB; 43°F (6.1°C) WB. Line Set @ 25ft (7.5m); Height Difference @ 0ft (0m). 2. COP for all temperatures is @ rated output except when rated output is not given. In that case, COP is @ max. output. 3. System continues to operate below rated outdoor temperature operating range, subject to varying conditions. System has no low temperature cutout. Capacity is not tested outside of the rated temperature range. | Master Group is not responsible for the accuracy and validity of any changes made to this document without the written authorization of Master Group. Specifications subject to change without notice.

DIMENSIONS & WEIGHTS		
Indoor	Net (WxDxH; in.)	43.31x30.47x9.80
	Gross (WxDxH; in.)	51.38x31.69x12.40
	Net Weight lbs kg	90.39 41
	Gross Weight lbs kg	105.82 48
Outdoor	Net (WxDxH; in.)	37.24x16.14x31.89
	Gross (WxDxH; in.)	42.91x19.69x34.84
	Net Weight lbs kg	124.78 56.6
	Gross Weight lbs kg	134.92 61.2

KEY FEATURES	
Rotary Inverter Compressor	<input type="checkbox"/>
Twin Rotary Inverter Compressor	<input checked="" type="checkbox"/>
Base Pan Heater	<input checked="" type="checkbox"/>
Crankcase Heater	<input checked="" type="checkbox"/>

INCLUDED ACCESSORIES	
KJR-120L(R1)/EFU1 - Wired Controller	

FAN				
Indoor	Turbo	High	Med.	Low
CFM		775	693	434
dB(A)		44	41	37
Indoor ESP Range inWG				0-0.64
Indoor Moisture Removal (l/h)				1.52
Outdoor Max. CFM				2235
Outdoor Max. dB(A)				59

OPTIONAL ACCESSORIES ⁴	
WF-60A1-F - Smart Port	<input type="checkbox"/>
KJR-120N(X6)/BGEF - Wired Controller	<input type="checkbox"/>
KJR-120N(X6W)/BGEF - Wired Controller	<input type="checkbox"/>
24VINTERFACEKITUNIVERSAL	<input type="checkbox"/>
	<input type="checkbox"/>
	<input type="checkbox"/>
	<input type="checkbox"/>
	<input type="checkbox"/>
	<input type="checkbox"/>
	<input type="checkbox"/>

INDOOR UNIT DRAWING

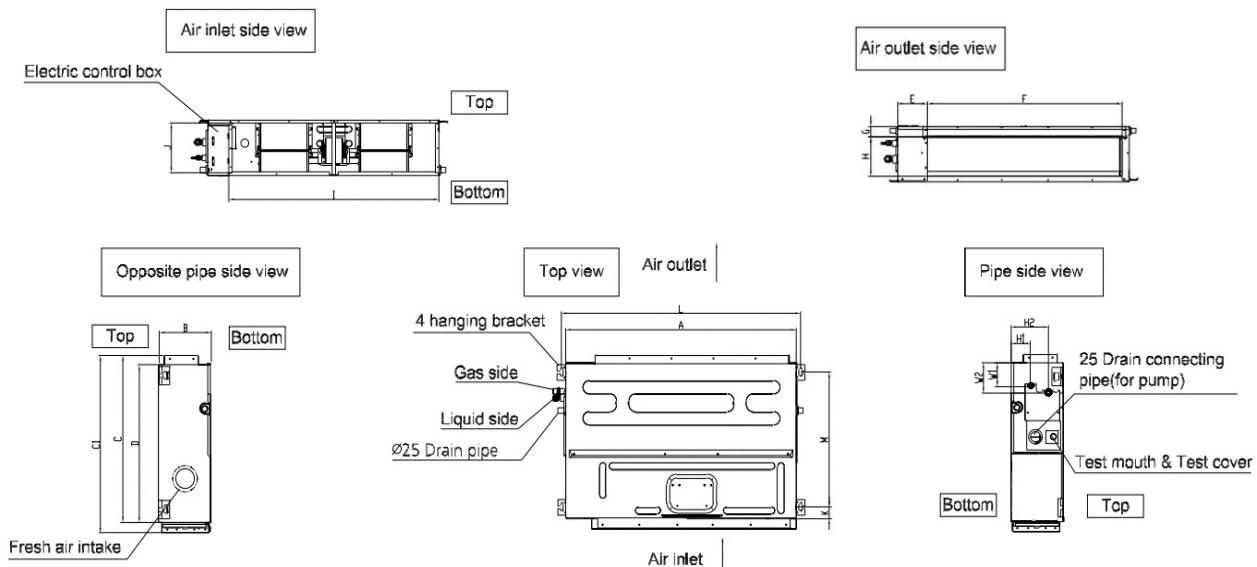

Tag	A	B	C	C1	D	E	F	G	H
inches	43.3	9.8	28.9	30.5	27.6	5.5	36.5	2	6.9
mm	1100	249	734	774	700	140	926	50	175
Tag	I	J	K	L	M	H1	H2	W1	W2
inches	39.4	9	2	44.9	23.5	3.1	5.9	5.1	6.1
mm	1001	228	50	1140	598	80	150	130	155

Drawing dimensions are nominal. Specifications subject to change without notice. 4. Connection of these accessories may require secondary items not listed; refer to full product literature.

OUTDOOR UNIT DRAWING

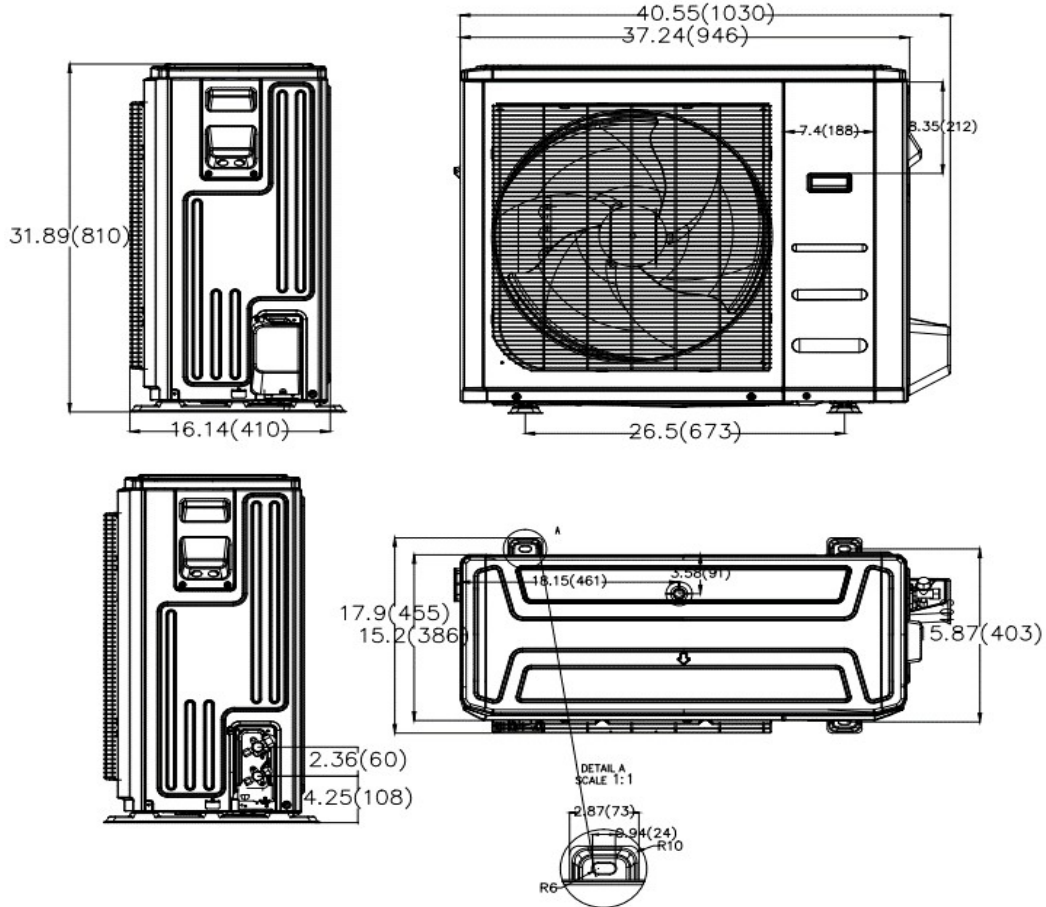

OUTDOOR UNIT CLEARANCES

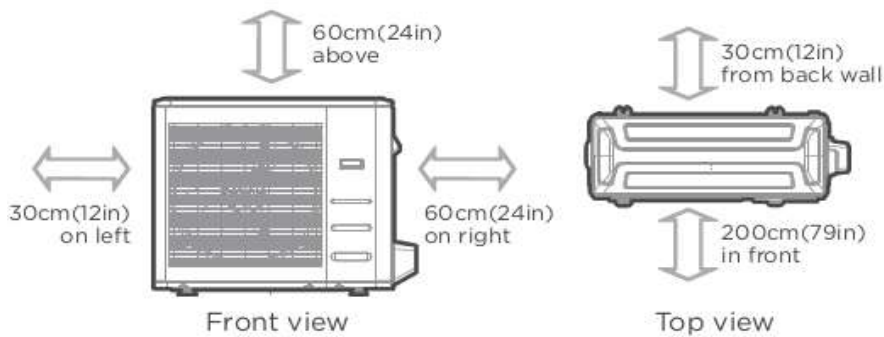

Note: Outdoor units must be elevated 12-24in. (30.5-61cm) above the surface below in heating applications to allow for snow clearance and defrost runoff. Follow local best-practices and guidelines.

Diagrams for reference only.

NOTES