

SUBMITTAL - 30,000BTU MULTI-POSITION AHU

Job Name: _____
Location: _____
Engineer: _____
Submitted By: _____
Submitted To: _____

Submitted For: _____ **Approval**
Reference **Construction**
Date: _____
Unit Tag: _____
Drawing No.: _____

WARRANTY

1 Year Parts & 5 Years Compressor

Terms & Conditions Apply.

TYPE

Air Source Heat Pump

Cold Climate Air Source Heat Pump

MODELS

Indoor FEA30HIAHUU230X7

Outdoor DEA30HOS20230E7

CAPACITY RANGE¹

Output (Btu/h)	Min.	Rated	Max.
Cooling	10000	30000	33600
Heating	8500	33000	34000

HEATING PERFORMANCE²

Output (Btu/h)	Min.	Rated	Max.
47°F (8.3°C)	8500	33000	34000
17°F (-8.3°C)	10000	21000	28600
5°F (-15°C)	7600	24000	25757
-22°F (-30°C)	7400	13700	13700

OUTDOOR TEMPERATURE OPERATING RANGE

Cooling	-15 ~ 50 °C	5 ~ 122 °F
Heating ³	-30 ~ 24 °C	-22 ~ 75 °F

LINE SET & REFRIGERANT

Liquid (in.)	3/8"	Gas (in.)	3/4"
Connection Type	Flared		
Pre-Charge Length (ft)	25		
Maximum Length (ft)	164.04		
Maximum Height Difference (ft)	82.02		
Refrigerant Type	R410A		
Pre-Charge (oz)	134.0412		
Additional Charge per Foot (oz)	0.69		
Oil Type	VG74	Oil Volume (ml)	1000
Drain Connection (inches)	3/4"		



Images for reference only.

CERTIFIED

AHRI NO.	
213081443	

EFFICIENCY RATINGS

SEER2	16.2			
EER2	10			
HSPF2 (4)	8.9			
HSPF2 (5)	7			
COP ²	47°F (8.3°C)	17°F (-8.3°C)	5°F (-15°C)	-22°F (-30°C)
	3.3	2.34	1.8	1.16

ELECTRICAL

Power Supply	(V/Ph/Hz)	208-230/1/60		
Voltage Range	(V)	187-253		
MCA (A)	23	Max Fuse (ODU) (A)	35	
Power Input (W)	Min.	Rated	Max.	
	Cooling	370	3060	3360
Heating	550	2930	3250	
Current (A)	Min.	Rated	Max.	
	Cooling	2.9	13.2	15
Heating	4	13.3	14.6	

1. Cooling Capacity Conditions: Indoor Temperature @ 80°F (26.7°C) DB; 67°F (19.4°C) WB with Outdoor Temperature @ 95°F (35°C) DB; 75°F (23.9°C) WB. Heating Capacity Conditions: Indoor Temperature @ 70°F (21.1°C) DB; 60°F (15.6°C) WB with Outdoor Temperature @ 47°F (8.3°C) DB; 43°F (6.1°C) WB. Line Set @ 25ft (7.5m); Height Difference @ 0ft (0m). 2. COP for all temperatures is @ rated output except when rated output is not given. In that case, COP is @ max. output. 3. System continues to operate below rated outdoor temperature operating range, subject to varying conditions. System has no low temperature cutout. Capacity is not tested outside of the rated temperature range. | Master Group is not responsible for the accuracy and validity of any changes made to this document without the written authorization of Master Group. Specifications subject to change without notice.

DIMENSIONS & WEIGHTS		
Indoor	Net (WxDxH; in.)	21.02x21.02x49.02
	Gross (WxDxH; in.)	24.41X26.57X52.50
	Net Weight lbs kg	129.19 58.6
	Gross Weight lbs kg	155.64 70.6
Outdoor	Net (WxDxH; in.)	37.24x16.14x31.89
	Gross (WxDxH; in.)	42.91x19.69x34.84
	Net Weight lbs kg	159.83 72.5
	Gross Weight lbs kg	169.75 77

KEY FEATURES	
Rotary Inverter Compressor	<input checked="" type="checkbox"/>
Twin Rotary Inverter Compressor	<input type="checkbox"/>
Base Pan Heater	<input checked="" type="checkbox"/>
Crankcase Heater	<input checked="" type="checkbox"/>

INCLUDED ACCESSORIES	
RG10A(D2S)/BGEFU1 - Remote Controller	
KJR-120N(X6W)/BGEF V1.2 - Wired Controller	
Adaptor for welding(3/8")	
Adaptor for welding(3/4")	

INDOOR UNIT DRAWING

FAN				
Indoor	Turbo	High	Med.	Low
CFM	1088	894	805	711
dB(A)		42	40.5	36.5
Indoor ESP Range inWG				0-0.80
Indoor Moisture Removal (l/h)				3.41
Outdoor Max. CFM				3000
Outdoor Max. dB(A)				60.5

OPTIONAL ACCESSORIES ⁴	
EAH-05B(UL) - 5kW Electric Heater Kit	<input type="checkbox"/>
EAH-10B(UL) - 10kW Electric Heater Kit	<input type="checkbox"/>
EAH-15B(UL) - 15kW Electric Heater Kit	<input type="checkbox"/>
	<input type="checkbox"/>
	<input type="checkbox"/>
	<input type="checkbox"/>
	<input type="checkbox"/>
	<input type="checkbox"/>
	<input type="checkbox"/>

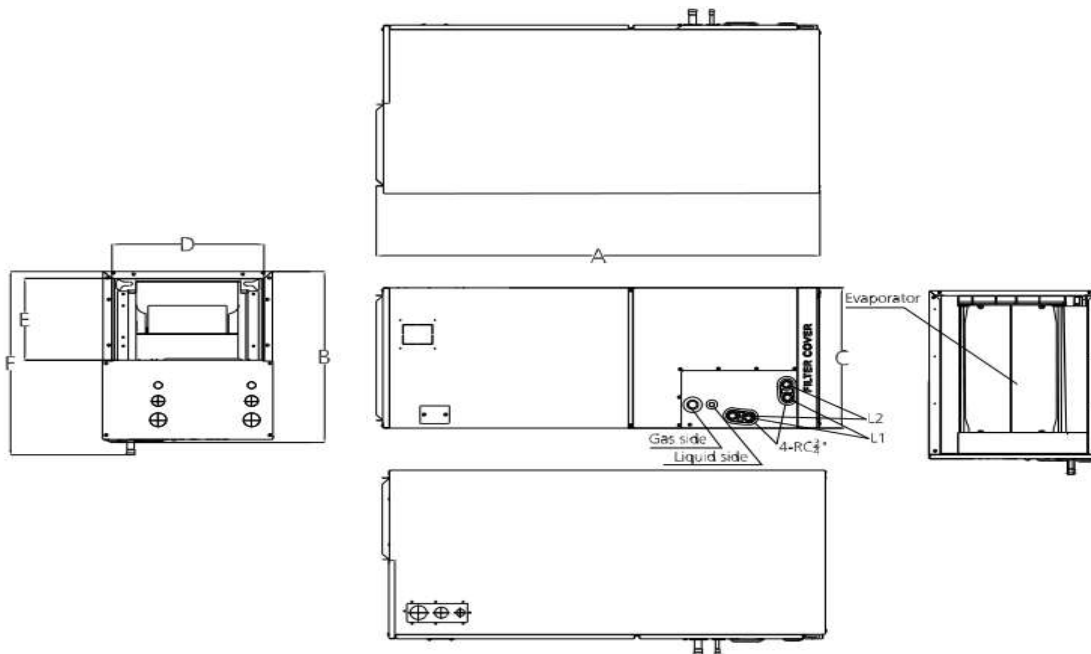

Dimensions D and E are air outlet dimensions.

Tag	A	B	C	D	E	F		L1	L2
inches	49	21	21	19-5/16	10-1/4	23		Main Drain	Overflow Drain
mm	1245	534	534	490	260	585			

Drawing dimensions are nominal. Specifications subject to change without notice. 4. Connection of these accessories may require secondary items not listed; refer to full product literature.

OUTDOOR UNIT DRAWING

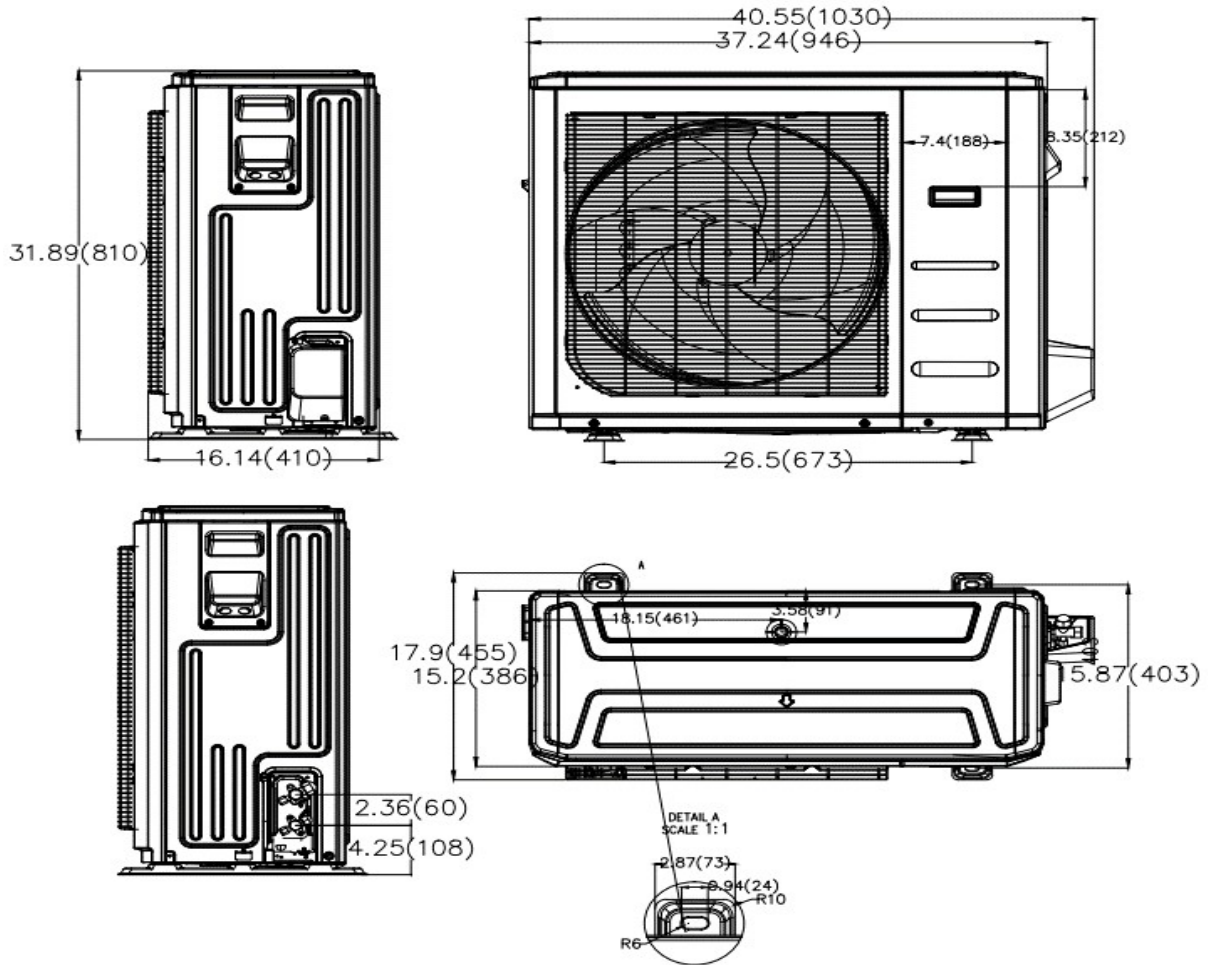

OUTDOOR UNIT CLEARANCES

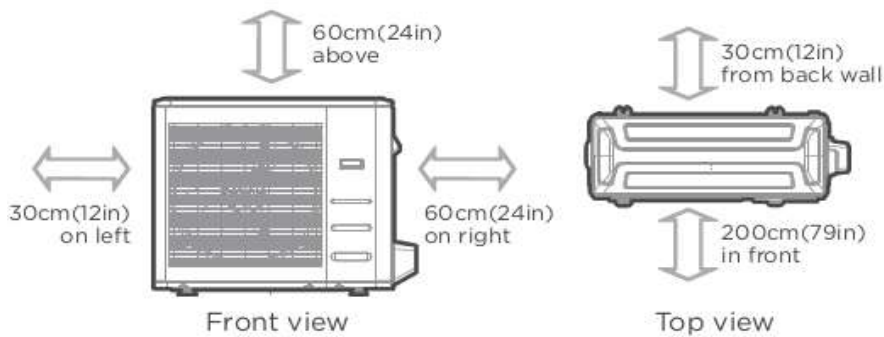

Note: Outdoor units must be elevated 12-24in. (30.5-61cm) above the surface below in heating applications to allow for snow clearance and defrost runoff. Follow local best-practices and guidelines.

Diagrams for reference only.

NOTES